

LEGENDA

VERSIONE MO - FORATURE STANDARD DISPONIBILI MO VERSION - STANDARD STUD HOLES AVAILABLE

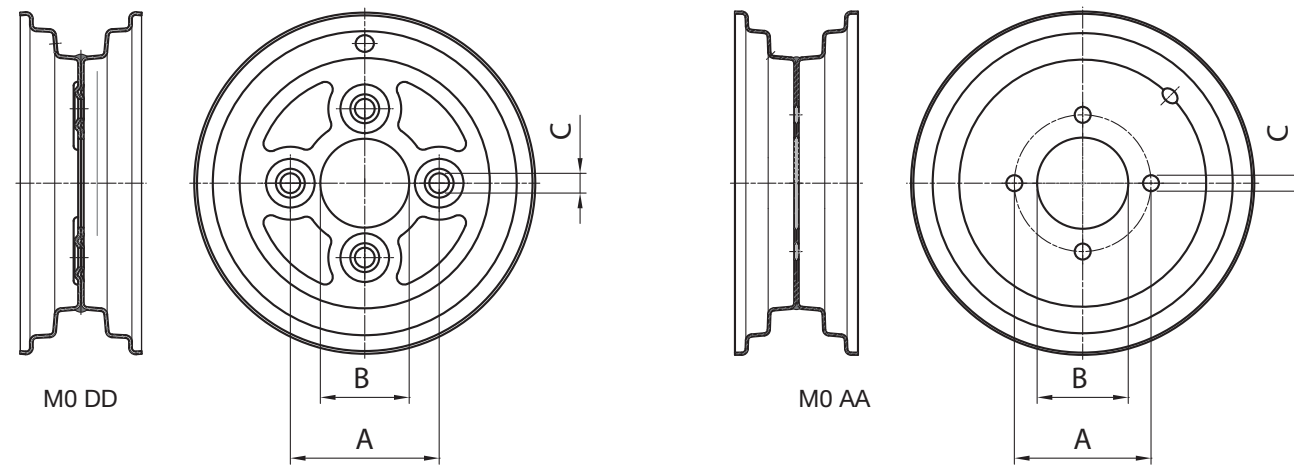

LE FORATURE STANDARD PREVEDONO LA SEDE CONICA O PIANA
THE STANDARD FIXING HOLES PROVIDE HAVE THE CONICAL OR PLAIN SEAT



CODICE CODE	B	A	C	FORI HOLES	TIPO TYPE	D	NOTE
	mm	mm	mm	mm	mm		
M0 1	40,5	65	9,5	3	AA		
M0 2	70	88	8,5	3	AA		3 FORI LEM
M0 3	70	88	10,5	3	AA		
M0 4	52	70	11	4	AA		VESPA
M0 5	55	85	13	4	AA		TOPOLINO
M0 6	58	98	13	4	AA		FIAT
M0 7	58	98	13,5	4	DD	90°	FIAT
M0 8	60	100	15	4	DD	60°	BMW
M0 9	60,4	101,6	13,5	4	AA		
M0 10	62	95	13	4	AA		BALILLA
M0 11	62	95	13,5	4	DD	90°	BALILLA
M0 12	64	100	15	4	DD	60°	
M0 13	85	115	12	4	DD	90°	FRANCIA
M0 14	85	130	15	4	AA		
M0 15	94	140	18,5	5	AA		5 FORI I.
M0 16	94	140	18,5	5	DD	90°	5 FORI I.
M0 17	106	140	18,5	5	DD	90°	5 FORI
M0 18	161	205	18,5	6	DD	90°	6 FORI I.

VERSIONI STANDARD

STANDARD VERSIONS

VERSIONE MO MO VERSION

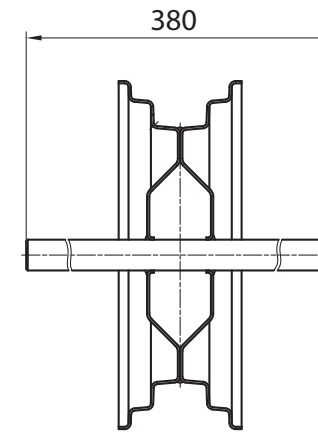

ALBERINO SALDATO Ø20
WELDED AXLE Ø20

CODICE CODE	D	L
	mm	mm
M2 1	20	75
M2 2	20	80
M2 3	25	80
M2 4	30	80

VERSIONE M2 M2 VERSION

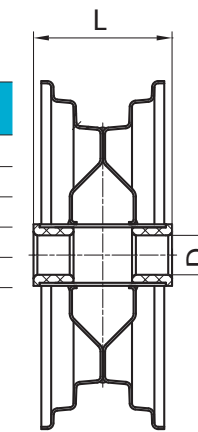

MOZZO CON BOCCOLE NYLON
HUB WITH NYLON BUSHING

VERSIONE M2R M2R VERSION

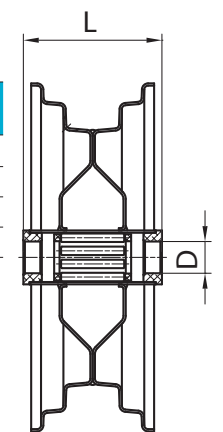

MOZZO CON CUSCINETTO A RULLI
HUB WITH ROLLER BEARINGS

CODICE CODE	D	L
	mm	mm
M2R 1	20	75
M2R 2	25	80
M2R 3	25	100

VERSIONE M3 M3 VERSION

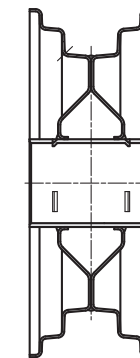

MOZZO SEDI CUSCINETTI
HUB WITH BALL BEARINGS SEAT

CODICE CODE	D	L
	mm	mm
M4 1	20	51
M4 2	20	80
M4 3	25	51
M4 4	25	80
M4 5	30	66

VERSIONE M4 M4 VERSION

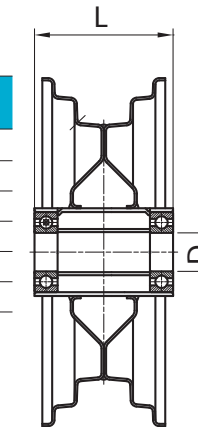

MOZZO CON CUSCINETTI A SFERA
HUB WITH BALL BEARINGS

VERSIONE M5 M5 VERSION

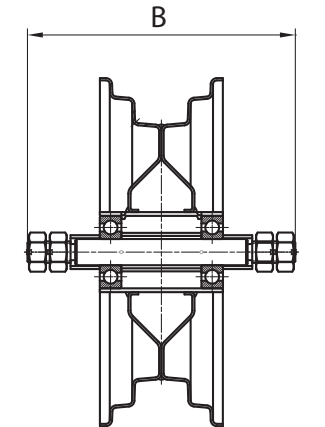

CUSCINETTI A SFERA + PERNO M14
BALL BEARINGS FORK AXLE M14

VERSIONE M6 M6 VERSION

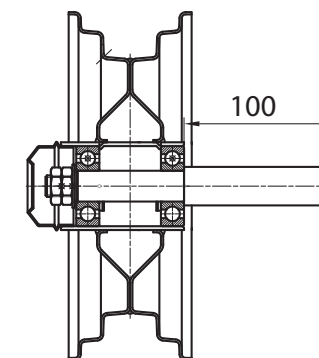

PERNO LATERALE Ø25
SIDE AXLE Ø25

VERSIONE TC TC VERSION

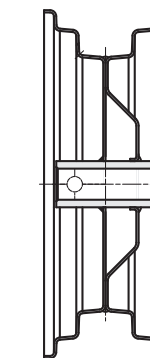

TUBO CILINDRICO FORO SPINA
PIPE WITH TRACTION HOLE

VERSIONE TCH TCH VERSION

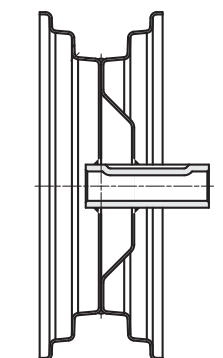

TUBO CILINDRICO SEDE CHIAVETTA
KEY SEAT PIPE